

# LA1-PH08 MANUAL

## Phone Holder

LA1-PH08 can be mounted on the rearview mirror base of the motorcycle. The motorcycle rider can mount a smartphone onto it for navigation. It is available to the smartphone screen between 4.7"-6.7".

1

Contents

### Contents:

The user can decide whether to use shock-absorbing pad, based on the thickness of the phone case.

- 1 Phone Holder. (T-PH08)
- 2 Shock-absorbing pad (1mm)
- 3 Ball Base. (T-BM01)

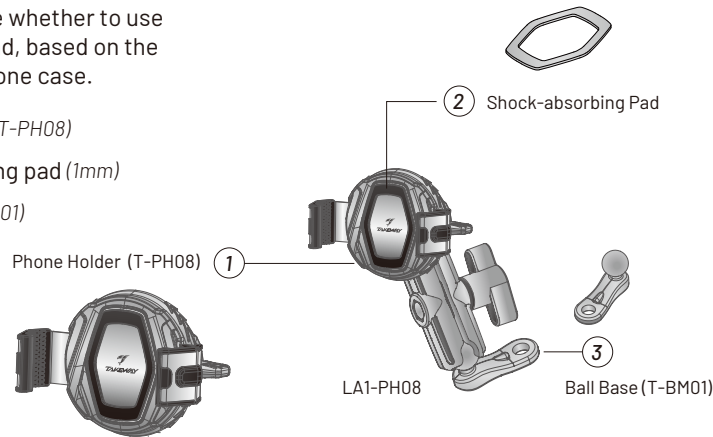

2

Installation of the shock-absorbing pad:

### 2-1 Installation of the shock-absorbing pad:

The user can decide whether to use the shock-absorbing pad or not, based on the phone case's thickness. Take off the releasing paper on the shock-absorbing pad. Place the combined piece on the phone holder bed.

Ensure your phone is placed within the grooved rubber padding area of the jaws.

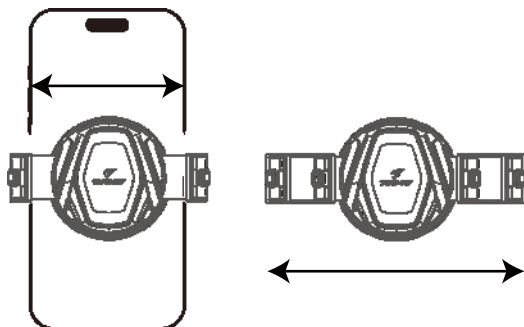
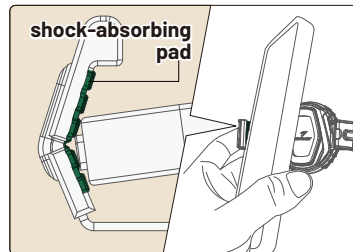
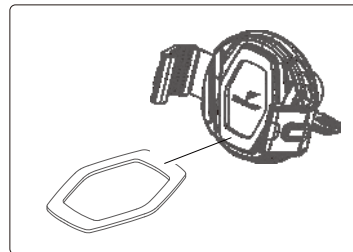

4

Assemble and operation

### Attention!

The shock-absorbing pad are NOT necessary to install. It depends on your phone thickness including the phone case. The most import is to make sure your smartphone seated **CLOSELY INTO THE PHONE HOLDER** before any further operation. A vacant space may increase the damage risk when riding and using the phone holder.

Close-fitting

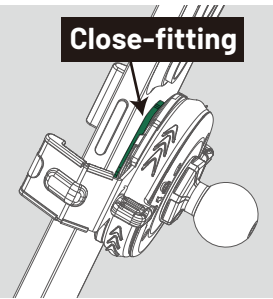

### Step 1.

Loosen up the nut of the rearview mirror and keep turning the mirror until you can take it off. Insert the ball mount of LA1-PH08 into the dismantled rearview mirror and screw the mirror back to the motorcycle. You can adjust the angle of the phone holder using the knob on the bracket.

Please check the curve between the dashboard and the rearview mirror base and adjust the the ball mount accordingly to get a proper angle (front/rear). If your rearview mirror base has a 8 mm screw, please use the enclosed 8 mm washer for mounting.

### Step 2.

#### Mounting the Phone

Insert your phone into the holder. Push it against the right jaw and apply pressure to the right. The both jaws will open symmetrically. Once the phone is positioned, release the holder to secure it in place. Rotate the rear safety lock to Position 1 to lock the phone in place. For additional security, rotate the safety lock to Position 2, applying extra pressure for a firm hold.

#### Removing the Phone

Reverse the steps: Rotate the safety lock to Position 0 to unlock. Remove the phone by gently releasing it from the jaws.

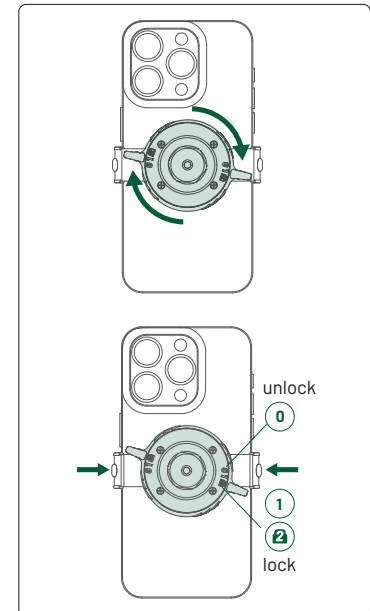
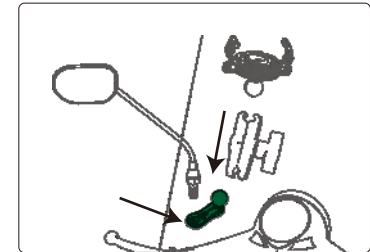

Note: When using the smart security lock, please do not put your finger between the clamping jaws (silver components) to avoid injury to your finger or compromise of the clamping strength.

< Dismantling >

**A** Unlock the smart security lock. Use one hand to push the corner sleeves open by applying force toward the lower right corner. Once the corner sleeves are expanded, you can easily take out your phone.

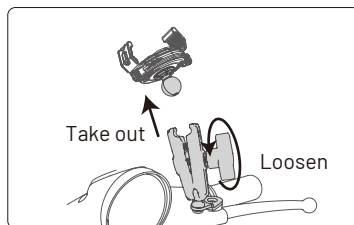

**B** Quick release universal bracket (Anti-theft feature):  
If the bracket will not be in use for a long time, you can dismantle it by using the quick release feature and store the bracket in a safe place. Instruction: Loosen the bracket knob. Take off the the ball-shaped mount of the phone holder. Use fingers to nip the top of the clamping bracket and the bracket will come off easily.

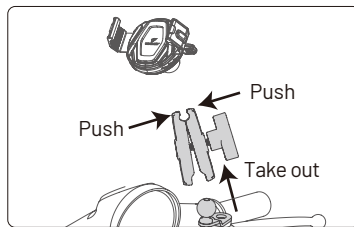

T-RC04 Quick release Ballhead for action camera

Put the action camera on T-RC04 Quick release ballhead.

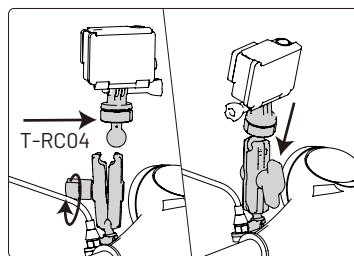
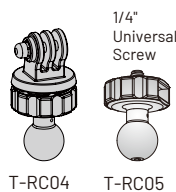

- \* Optional accessory: T-RC04
- \* Optional accessory T-RC05

Optional Accessory

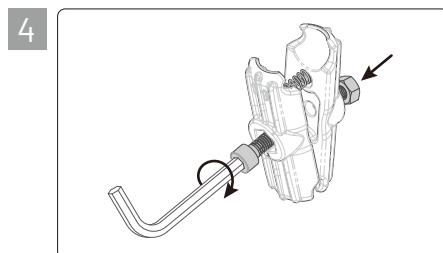
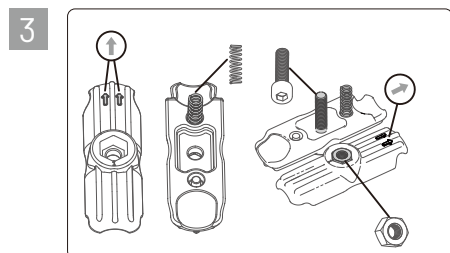
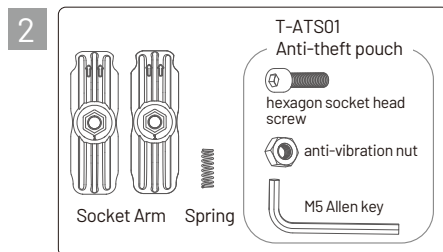
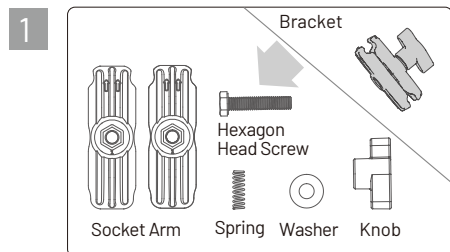

Note the direction!  
The circle of the anti-vibration hexagonal nut is outward.

Place and assemble the spring, the screw, and the screw nut in the right position. Use an Allen key to tighten up the screw.

1. Before setting the security lock, use one hand to pull down the lower sleeve corner to check whether the gliding is smooth.
2. Fasten the security lock, while keeping the sleeve corners open. Check whether the extended sleeve corners are firmly fixed and do not glide.
3. Unfasten the security lock. The sleeve corners will automatically return to their original positions.

\* Inappropriate testing and use might damage the phone holder structure. Any damage due to this inappropriate handling is not covered by the standard limited warranty.

\* If you have any concerns about the product use, please stop using it immediately and contact our customer service.

Customer Service E-Mail:  
info@takeway.tw

The standard limited warranty is valid for one year, from the original date of purchase for a consumer or a private purchaser (the warranty covers only the primary phone holder and does not include the attached accessories).

Please be aware of this condition and use the phone holder at your discretion.

This product is covered by product liability insurance. However, any personal injury and property damage caused by misuse of and physical abuse to the product is not covered, and Takeway® takes no responsibility for such injury and damage.

Please carefully read the product manual and correctly use the phone holder.

**! WARNINGS**

**This product is designed to reduce the vibration's impact on the smartphone. However, it does not function as optical image stabilization and cannot completely eliminate the vibration's impact on the optical lens.**  
**Please be aware of this condition and use the phone holder at your discretion.**



**LA1-PH08 MANUAL**  
Phone Holder

Before using the product for the first time, please read through the user guide.  
Please use this product correctly after fully understanding the contents of the user guide.

All information described in this user guide is based on the test standard of Takeway®. Sorry for the inconvenience caused if there are any errors. The design and specifications of this product are subject to change without notice.

Patented product,  
counterfeiting not allowed

**EHOMA INDUSTRIAL CORPORATION**

TEL:+886-4-2406 5031  
info@takeway.tw  
www.takeway.tw